

# SHOPFAN

PART OF THE BASIC 6 FAMILY

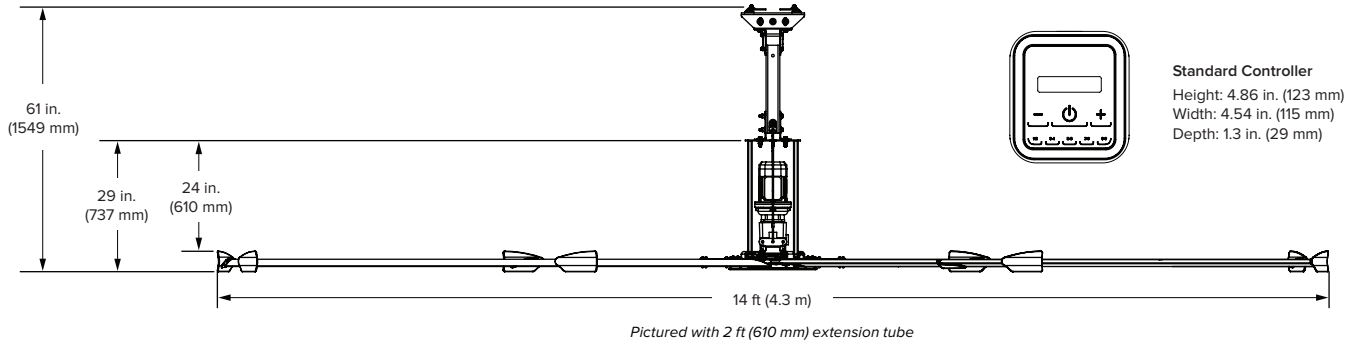

Lightweight and efficient, ShopFan by Big Ass Fans is a powerful and economical fan package for workshops, small manufacturing facilities, and industrial spaces. Easy installation, superb performance, and year-round energy savings — just what you'd expect from Big Ass Fans.



## Technical Specifications

Model	Diameter (A)	Weight <sup>1</sup>	Max speed	Airfoil clearances <sup>2</sup>	Input power and required breaker	Max amps	Motor	Max Operating Temperature
PF62-14	14 ft (4.3 m)	192 lb (87.1 kg)	96 RPM	10 ft (3 m) above floor 2 ft (0.6 m) on sides 5 ft (1.5 m) below ceiling deck	200–240 VAC, 50/60 Hz, 1 φ, 20 A	13.3 A	1.5 hp (1.1 kW)	104°F (40°C)

## Construction Features

Airfoils	Motor and Drive <sup>3</sup>	Certifications	Mounting	Multi-Point Safety
Six patented airfoils (mill finish) Cuffed winglets eliminate wind noise (BAF yellow)	Industrial-grade motor and gearbox feature inline helical-cut gears for efficient, durable, and reliable operation Onboard NEMA 4X variable speed drive	 UL Standard 507 and CSA Standard 22.2 No. 113	2 ft (30.48 cm) extension tube Standard upper mount installs to I-beams and bar joists	Double safety cable system, airfoil retainers, hub safety clips, Grade 8 hardware, and fire relay (must be wired if required by local code)

## Standard Controller

Construction	Controls
Made from durable UV-resistant materials Rated IP55 Intuitive touchscreen interface	On/Off and variable speed control Password protection Powered by fan drive

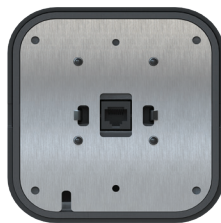

<sup>1</sup> Weight does not include mount or extension tube.  
<sup>2</sup> Measure the distance from the tip of the winglet to the ceiling or major obstruction.  
<sup>3</sup> The VFD is not preinstalled on the fan. Mounting the VFD onboard the fan requires field installation.

Lead times may vary.  
See full warranty for coverage information.



USA  
BIGASSFANS.COM  
877-244-3267

CANADA  
BIGASSFANS.COM  
844-924-4277

AUSTRALIA  
BIGASSFANS.COM/AU  
1300 244 277

SINGAPORE  
BIGASSFANS.COM/SG  
65 6709 8500